



# indoseals™

An associate of ND Thakare  
ISO 9001-2015



*Mechanical Seals Total Solutions*

# Double Mechanical Seal - ISPL 2408

**Applications:**

- Unbalanced multispring, double seal
- Easy to install and replace
- Independent on direction of rotation
- Pumps handling highly volatile and toxic fluid
- Slurry, abrasive applications

The seal is a combination of two conventional seals installed back to back inside stuffing box. Combinations like unbalanced / unbalanced, balanced / balanced, unbalanced / balanced can be provided as required. A compatible clean liquid with pressure higher than inside fluid pressure is circulated to reduce heat generated on the seal face. Various seal face materials are offered to suit different service conditions.

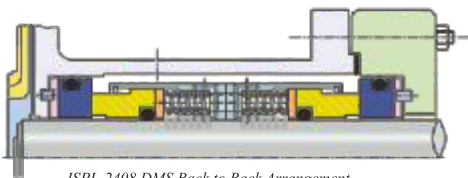

ISPL-2408 DMS Back to Back Arrangement

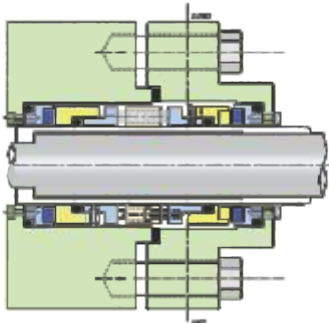

ISPL-2408A Back to Back Arrangement

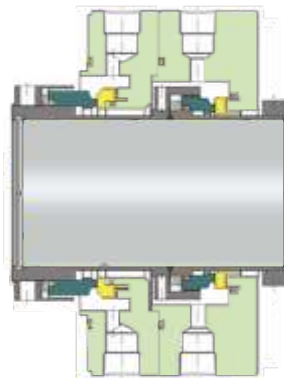

ISPL-2408C Tandem Arrangement

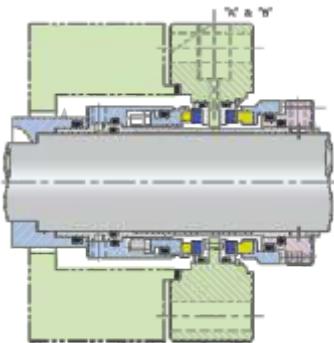

ISPL-2408B DMS Face to Face Arrangement

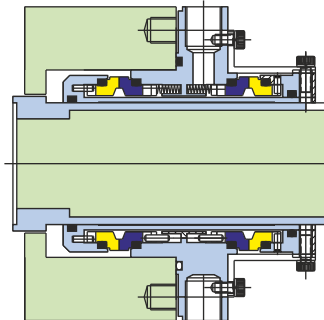

ISPL-2408 D



Certified By:



Use Indoseals....avoid plant pollution



- Nashik
- Pune
- Mumbai
- Kolhapur
- Hyderabad
- Bangalore
- Vijaywada
- Chennai
- Ahmedabad
- Barodra
- Kolkata
- New Delhi
- Sharanpur
- Lucknow
- Raipur
- Jaipur

Contact us:

For Sales:  
[sales@indoseals.com](mailto:sales@indoseals.com)  
Cell No.: +91 7447439162

For Services:  
[service@indoseals.com](mailto:service@indoseals.com)  
Cell No.: +91 9881301631



An associate of ND Thakare

# Indoseals P. Ltd.

Mfgs. of Mechanical seals & spares, Rotary unions

Regd. Office & factory: W-97A, First Floor, MIDC, [behind Hardy Spicer] Ambad,  
Nashik - 422010, Maharashtra, INDIA  
Phone: +91 253 2384705; +91 253 2384575  
Fax: +91 253 2384705, Cell: +91 9881301631  
e-mail: [sales@indoseals.com](mailto:sales@indoseals.com) ; [info@indoseals.com](mailto:info@indoseals.com); Website: [www.indoseals.com](http://www.indoseals.com)

Certified By:

