

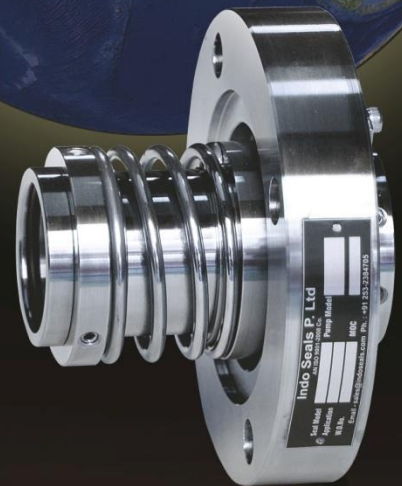

# indoseals<sup>TM</sup>

An associate of ND Thakare  
ISO 9001-2015



*Mechanical Seals Total Solutions*

## Grinding Mill Double Cartridge Seal - ISPL 2427

- Double seal
- Independent on direction of rotation
- Spring product protected
- Temperature maintained by cooling oil

### Applications:

- Commonly used for paint, slurry / abrasive liquid in grinding mills

Double multi-spring pusher, cartridge seal, specially designed to operate in slurries where corrosive, toxic or volatile liquids are being handled & a single seal is not acceptable. Cooling liquid provided to maintain temperature & minimum friction between both faces. Spring loaded stationary maintain equal pressure on both side because of common springs.

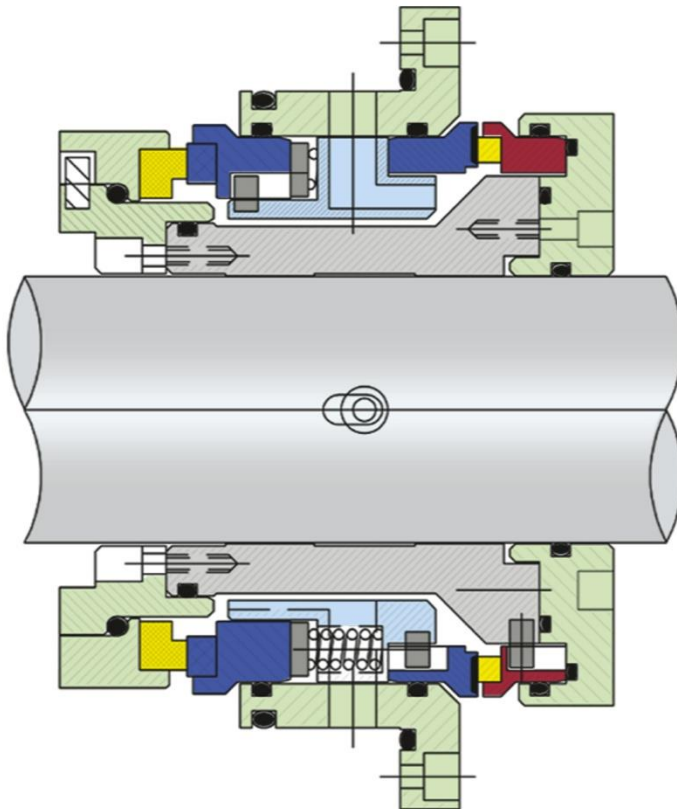

ISPL-2427 DMS for Grinding Mills

Certified By:



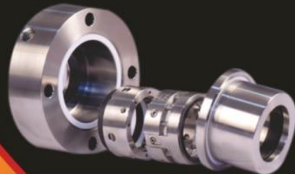
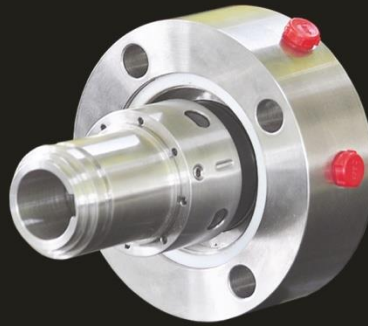

- Nashik
- Pune
- Mumbai
- Kolhapur
- Hyderabad
- Bangalore
- Vijaywada
- Chennai
- Ahmedabad
- Barodra
- Kolkata
- New Delhi
- Sharanpur
- Lucknow
- Raipur
- Jaipur

Contact us:

For Sales:

[sales@indoseals.com](mailto:sales@indoseals.com)  
Cell No.: +91 7447439162

For Services:

[service@indoseals.com](mailto:service@indoseals.com)  
Cell No.: +91 9881301631



An associate of ND Thakare

# Indoseals P. Ltd.

Mfgrs. of Mechanical seals & spares, Rotary unions

Regd. Office & factory: W-97A, First Floor, MIDC, (behind Hardy Spicer) Ambad,  
Nashik - 422010, Maharashtra, INDIA  
Phone: +91 253 2384705; +91 253 2384575  
Fax: +91 253 2384705, Cell: +91 9881301631  
e-mail: [sales@indoseals.com](mailto:sales@indoseals.com) ; [info@indoseals.com](mailto:info@indoseals.com); Website: [www.indoseals.com](http://www.indoseals.com)

Certified By:

